

JOINT USE

| DRAWING NUMBER | SHT. | DRAWING TITLE | DWG REV. | BOM REV. |
|----------------|-------|---|----------|----------|
| A-28-00 | 1 | GENERAL INFORMATION | F | - |
| A-28-01 | 1 | JOINT USE CONFIGURATION | C | - |
| A-28-02 | 1 – 2 | JOINT USE POLE PLACEMENT | 0 / A | - |
| A-28-03 | 1 | BONDED CONNECTION OF MESSENGER TO EXISTING GROUND RISER | B | - |
| A-28-04 | 1 | JOINT USE BONDING WHERE THERE IS NO GROUND RISER | A | - |
| A-28-05 | 1 – 2 | TRANSFER MESSENGER | A | A |

SaskPower - DISTRIBUTION STANDARDS

| | | | |
|---------------------------|------------|------------------------|---------------------|
| APPROVAL | DESIGN CHK | DRN. LM | INDEX |
| L MOEN | L MOEN | CHKD. LM | |
| | | 2020-11-25 | |
| DATE OF ISSUE: 2020-12-18 | | DRAWING NO: A-28-INDEX | SHEET 1 of 1 REV. J |

JOINT USE

1. THIS SECTION INTENDS TO SHOW ONLY THE PHYSICAL CONFIGURATION AND BONDINGS REQUIREMENTS FOR POLES DESIGNATED TO BE JOINT USE. THE JOINT USE SPACE IS AN ALLOCATED AREA OF 0.6m TYPICALLY FOR ALL COMMUNICATION CIRCUITS INCLUDING TELEPHONE, CABLE TELEVISION, AND VARIOUS SIGNAL CIRCUITS.
2. FORMAL JOINT USE AGREEMENTS ARE IN EFFECT THAT DETAIL THE REQUIREMENTS OF POLE PLACEMENT (AND RELOCATION) RELATIVE TO COMMUNICATION EQUIPMENT. THESE MUST BE REFERRED TO BEFORE ANY POLE OR LINE CHANGES ARE MADE SINCE THERE ARE A NUMBER OF DETAILS INVOLVED THAT CANNOT BE COVERED IN THIS STANDARD.
3. WHEN SPANS GREATER THAN 46m ARE INVOLVED, DISTRIBUTION ENGINEERING IN REGINA SHOULD BE CONTACTED. NOT ONLY WILL CLEARANCES BETWEEN OUR CIRCUITS AND THE COMMUNICATIONS CIRCUITS BE INVOLVED BUT POLE STRENGTH AND ALLOWABLE GUYING MAY CHANGE.
4. FOR CLEARANCES OF CONDUCTORS AND COMMUNICATION CIRCUITS IN MID-SPAN, CROSSING CONDUCTORS AND WITH GUYS, ETC. SEE SECTION C-24-02.
5. LOCATION FOR BONDING WILL BE IDENTIFIED BY THE COMMUNICATION COMPANY PRIOR TO CONSTRUCTION.
6. ONLY URBAN DISTRIBUTION POLES WILL BE CONSIDERED FOR JOINT USE.
7. UNDERGROUND COMMUNICATION TAKE OFFS ARE NOT ALLOWED ON POLES WHERE GROUND OPERATED SWITCHES ARE PRESENT.
8. JOINT USE ATTACHMENTS SHALL BE LIMITED TO A MAXIMUM OF THREE (3) POSITIONS, WITH EACH POSITION HAVING ONLY ONE (1) JOINT USE LICENSEE. SUBSEQUENT POTENTIAL OR EXISTING LICENSEES ARE NOT PERMITTED TO ATTACH ON POSITIONS ALREADY OCCUPIED BY ANOTHER LICENSEE. EACH POSITION SHALL HAVE A MAXIMUM DIAMETER OF 50MM (2"), A MAXIMUM PER UNIT SUMMER WEIGHT OF 4.89 KG/M, AND MAXIMUM TENSION OF ICED (12.5MM RADIAL ICE) CONDUCTOR AT -20°C OF 8.9KN (2000 LBF). ENSURE ABSOLUTE MINIMUM CLEARANCE IS 5.45 M UNDER ICING CONDITIONS.

| | | | | |
|---|-----------------------------|----------------------------|----------------------------|-----------------------|
| SaskPower - DISTRIBUTION STANDARDS | | | | |
| APPROVAL L MOEN | DESIGN CHK L MOEN | DRN. LM | GENERAL INFORMATION | |
| | | CHKD. LM | | |
| | | 2020-04-28 | | |
| DATE OF ISSUE: 2020/05/12 | | DRAWING NO: A-28-00 | | SHEET 1 of 1 REV. F |

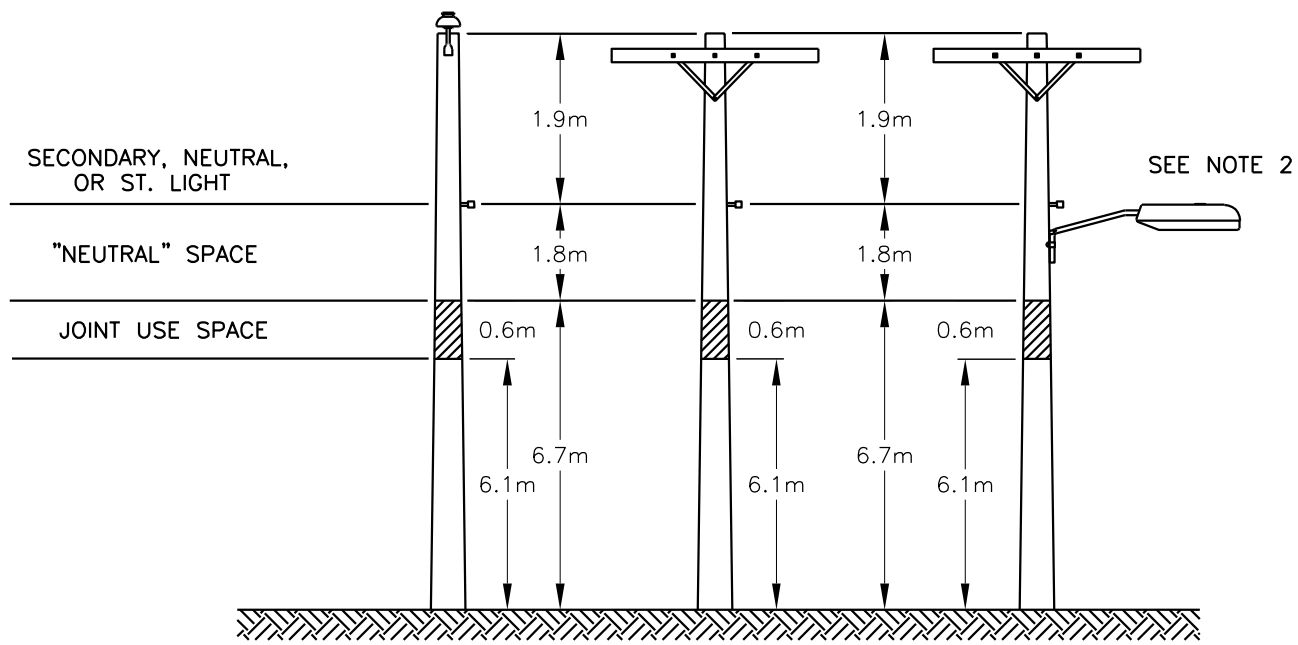

MINIMUM 12.2 POLE HEIGHT (SEE NOTE 1 AND 4)
 THESE SEPARATIONS ARE FOR MAXIMUM SPANS OF 46m
NEW CONSTRUCTION

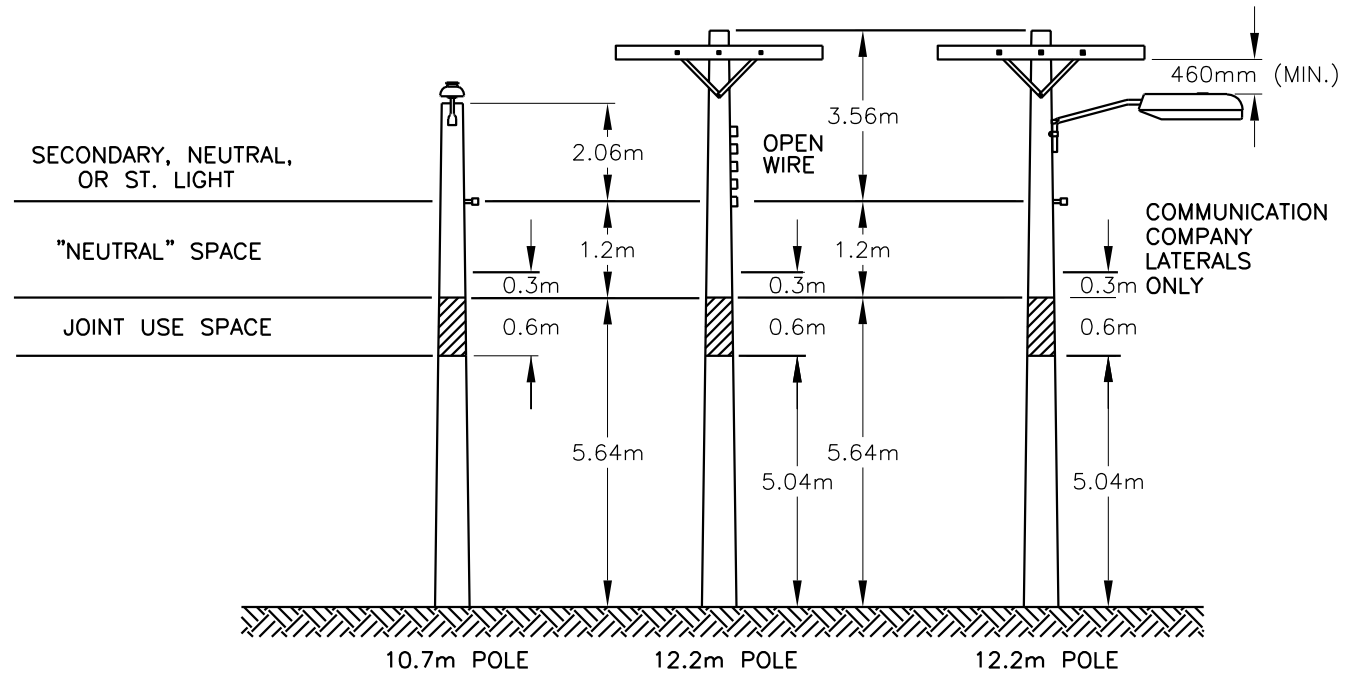

CONSTRUCTION PRIOR TO 1987

- NOTE:
1. CLEARANCES SHOWN ARE MINIMUM VALUES.
 2. IF DUE TO MOUNTING HEIGHT REQUIREMENTS A STREET LIGHT BRACKET IS WITHIN 1m OF THE TOP OF THE JOINT USE SPACE, THEN THE BRACKET MUST BE GROUNDED. SEE SECTION A-20-XX.
 3. FOR OTHER CLEARANCES REFER TO SECTION C-24-02.
 4. DIFFERENCE IN ELEVATION BETWEEN TOP OF ADJACENT POLES SHALL BE 0.65m MAXIMUM.
 5. FOR SENTINEL LUMINAIRES, SEE NOTE A-20-04.
 6. ALL DIMENSIONS ARE IN MILLIMETERS UNLESS OTHERWISE INDICATED.

SCALE: N.T.S. A28_01_01

| | | | | | |
|---|-------------|--------------|-------------------------|--------------|--------|
| SaskPower – DISTRIBUTION STANDARDS | | | | | |
| APPROVAL | DESIGN CHK. | DRN.E.GOTANA | JOINT USE CONFIGURATION | | |
| L.MOEN | O.FRANCIS | CHKD. | | | |
| | | 2020-09-28 | | | |
| DATE OF ISSUE | 2020-12-18 | DRAWING NO. | A-28-01 | SHEET 1 of 1 | REV. C |

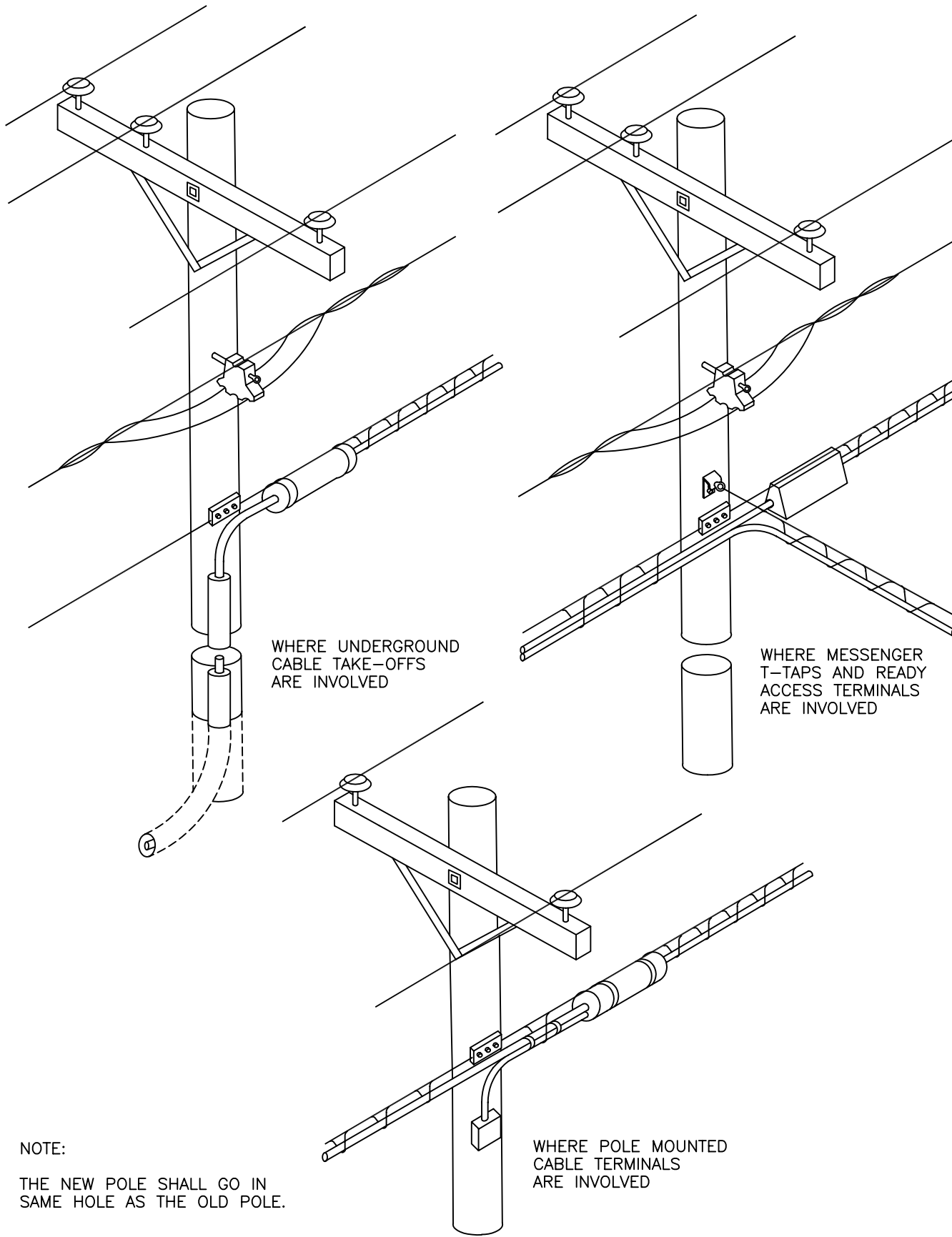

WHERE UNDERGROUND
CABLE TAKE-OFFS
ARE INVOLVED

WHERE MESSENGER
T-TAPS AND READY
ACCESS TERMINALS
ARE INVOLVED

WHERE POLE MOUNTED
CABLE TERMINALS
ARE INVOLVED

NOTE:
THE NEW POLE SHALL GO IN
SAME HOLE AS THE OLD POLE.

SCALE: N.T.S. ALL DIMENSIONS ARE IN MILLIMETRES UNLESS OTHERWISE INDICATED

SASKATCHEWAN POWER CORP. – DISTRIBUTION ENGINEERING STANDARDS

| | | | | |
|------------------------|---------------------|-------------|--------------|--------------------------|
| DRN. DK | DESIGN CHK. | SAFETY APP. | APPROVAL | JOINT USE POLE PLACEMENT |
| CHKD. FTK | | | | |
| DATE 86-11-29 | DATE | DATE | DATE | |
| DATE OF ISSUE 87-02-01 | DRAWING NO. A-28-02 | | SHEET 1 of 2 | REV. 0 |

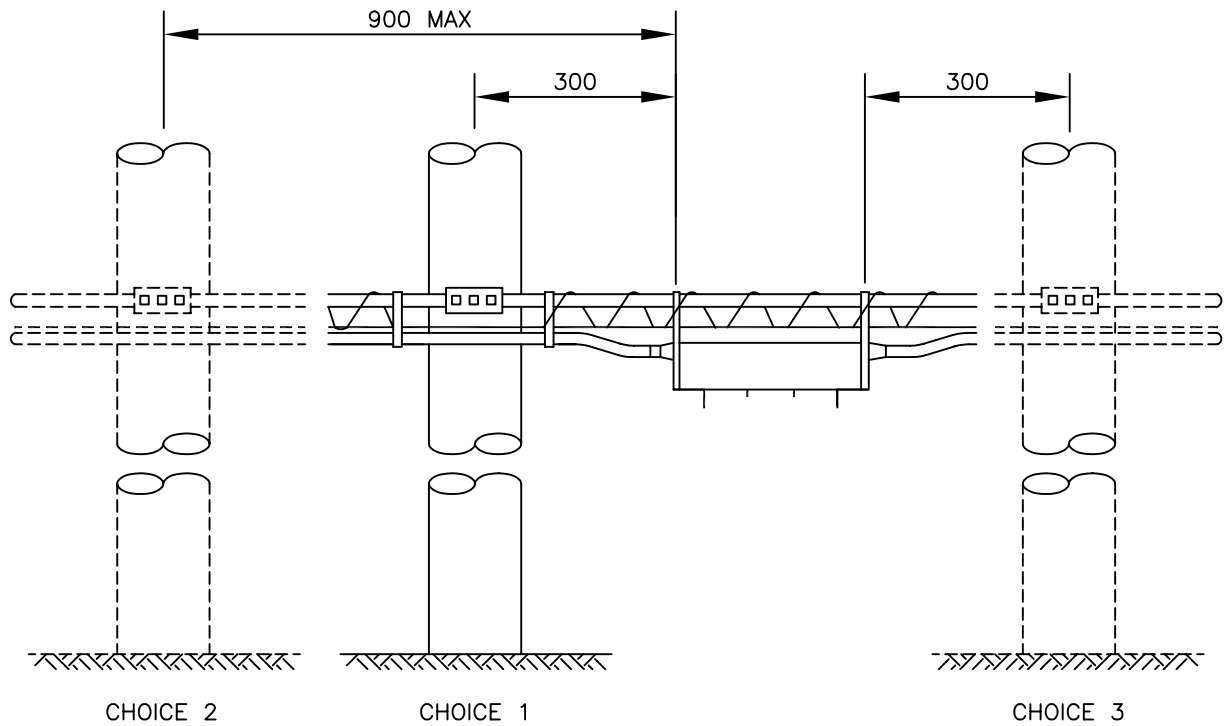

NOTE:
THE PREFERRED LOCATION OF READY ACCESS TERMINALS IS TO THE RIGHT SIDE OF THE POLE AS VIEWED FROM THE CABLE SIDE.

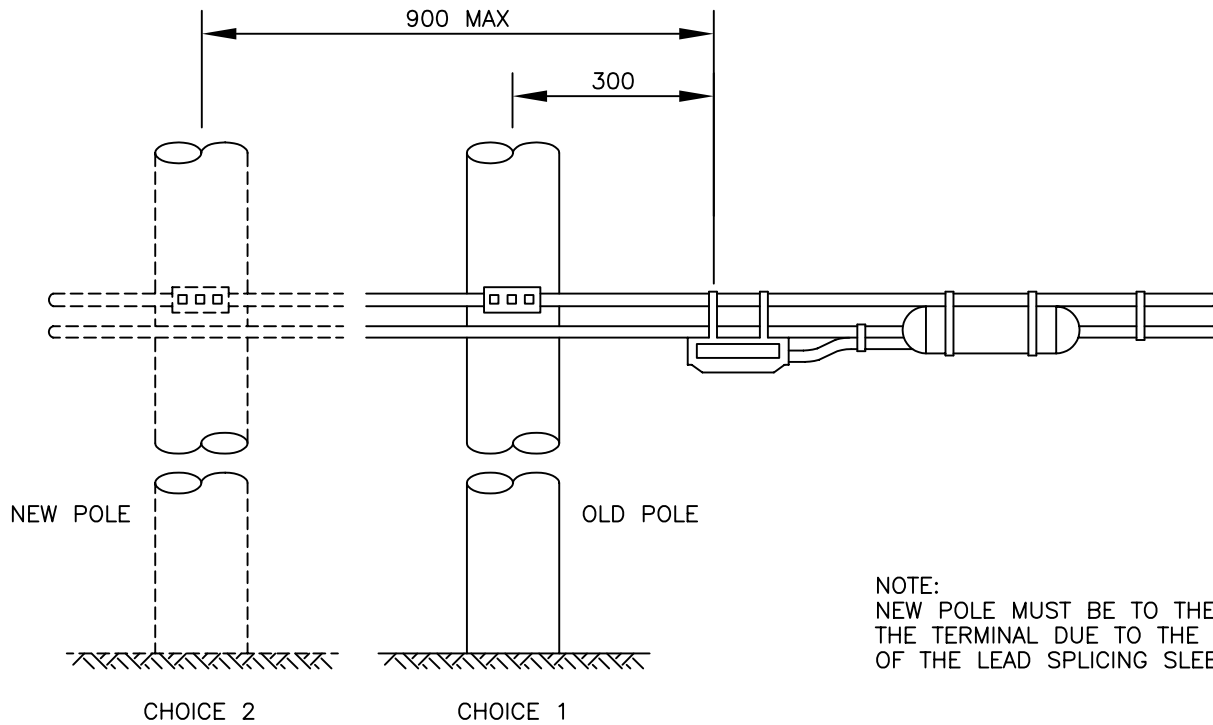

NOTE:
NEW POLE MUST BE TO THE LEFT OF THE TERMINAL DUE TO THE LOCATION OF THE LEAD SPLICING SLEEVE.

SCALE: N.T.S. ALL DIMENSIONS ARE IN MILLIMETRES UNLESS OTHERWISE INDICATED

SaskPower – DISTRIBUTION STANDARDS

| | | | | |
|---------------|-------------|-------------|---------------------|--------------------------|
| DRN. DK | DESIGN CHK. | SAFETY APP. | APPROVAL | JOINT USE POLE PLACEMENT |
| CHKD. | | | | |
| DATE | DATE | DATE | DATE | |
| DATE OF ISSUE | | | DRAWING NO. A-28-02 | SHEET 2 of 2 |
| | | | | REV. A |

| NO. | CODE | QTY. | MATERIAL |
|-----|---------|-------|-------------------------|
| 1 | 1-85-02 | 2 | STAPLE MOULDING |
| 2 | 2-83-04 | 300mm | WIRE #4/7 STR. BARE CU. |
| 3 | 5-09-XX | 2 | CRIMPIT TO SUIT |

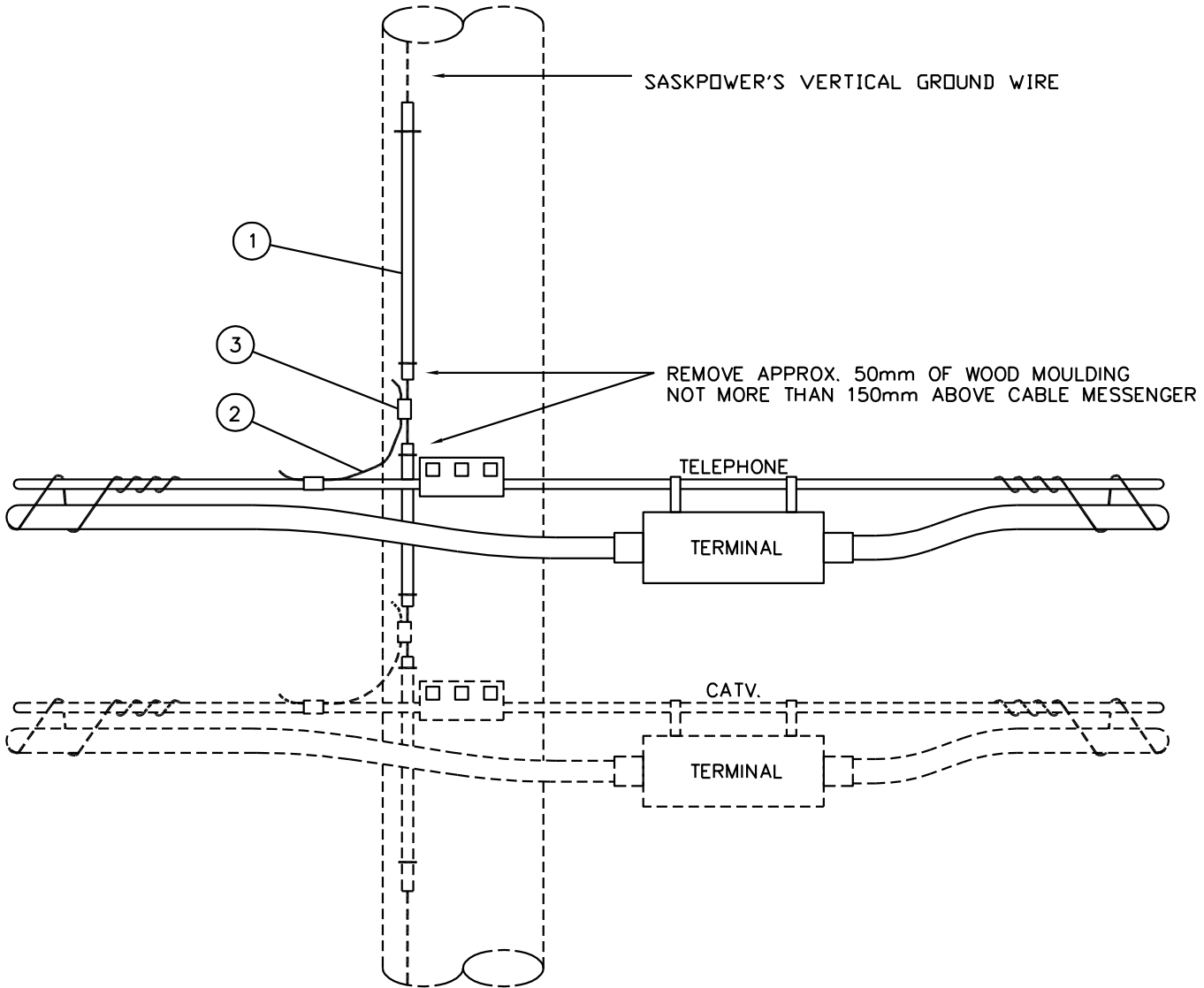

NOTE:

1. WHERE NO MOLDING IS ENCOUNTERED WHEN BONDING IS DONE, INSTALL MINIMUM 1m ABOVE AND 1m BELOW THE JOINT USE SPACE.

SCALE: N.T.S. ALL DIMENSIONS ARE IN MILLIMETRES UNLESS OTHERWISE INDICATED

SaskPower – DISTRIBUTION STANDARDS

| | | | |
|---------------------------|-------------|------------------------------------|---|
| APPROVAL | DESIGN CHK. | DRN. A.GATZKE CHKD.T.VENTOCILLA | BONDED CONNECTION OF MESSENGER TO EXISTING GROUND RISER |
| | | | |
| DATE OF ISSUE: 2011-04-01 | | DRAWING NO. A-28-03 | SHEET 1 of 1 |
| | | | REV. B |

| NO. | CODE | QTY. | | MATERIAL |
|-----|---------|------|----|-------------------------|
| | | A | B | |
| 1 | 1 85 02 | 5 | 4 | STAPLE MOULDING |
| 2 | 2 27 00 | 1 | 1 | MOULDING GRD. WIRE |
| 3 | 2 83 04 | 4m | 3m | WIRE #4/7 STR. BARE CU. |
| 4 | 5 09 XX | | | CRIMPIT TO SUIT |

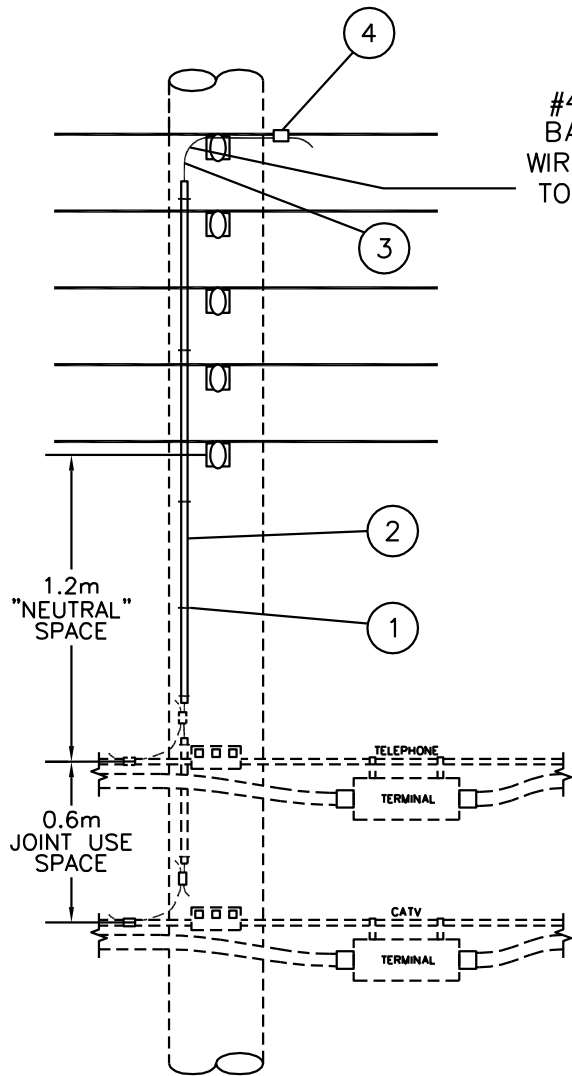

A
OPEN WIRE
SECONDARY

#4/7 STRAND
BARE GROUND
WIRE CONNECTED
TO SECONDARY
NEUTRAL

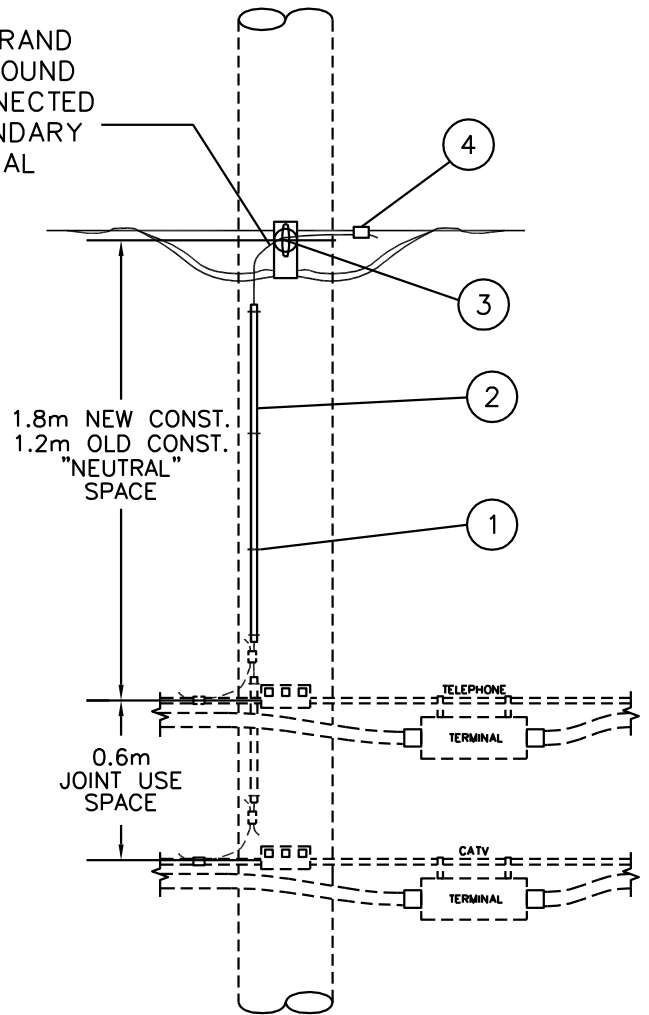

B
Tx OR Qx
SECONDARY

SCALE: N.T.S. ALL DIMENSIONS ARE IN MILLIMETRES UNLESS OTHERWISE INDICATED

SaskPower – DISTRIBUTION STANDARDS

| | | |
|----------|-------------|------------------------------------|
| APPROVAL | DESIGN CHK. | DRN. A.GATZKE CHKD.T.VENTOCILLA |
|----------|-------------|------------------------------------|

JOINT USE BONDING
WHERE THERE IS NO
GROUND RISER

DATE OF ISSUE: 2011-04-01

DRAWING NO. A-28-04

SHEET 1 of 1

REV. A

BILL OF MATERIAL

| ITEM NO. | CODE NO. | QUANTITY | DESCRIPTION |
|----------|------------------------------|----------|---|
| 1 | COMMUNICATION COMPANY | 2 | WASHER SQUARE - 2 1/4" x 2 1/4" x 13/16" HOLE |
| 2 | COMMUNICATION COMPANY | 1 | BOLT - 5/8" X 14" |
| 3 | COMMUNICATION COMPANY | 1 | CLAMP SUSPENSION MESSENGER - 3 BOLT |
| 4 | COMMUNICATION COMPANY | 1 | NUT - 5/8" |
| | | | <p>NOTE:</p> <p>1. COMMUNICATION COMPANY TO SUPPLY MATERIAL FOR EACH IDENTIFIED PROJECT</p> |

SaskPower - DISTRIBUTION STANDARDS

| | | | |
|----------------------------------|-------------|----------------------------|---------------------------|
| DRN. | DESIGN CHK. | APPROVAL | TRANSFER MESSENGER |
| CHKD. | | | |
| DATE | DATE | DATE | |
| DATE OF ISSUE: 2003/05/30 | | DRAWING NO: A-28-05 | SHEET 1 OF 2 |
| | | | REV. A |

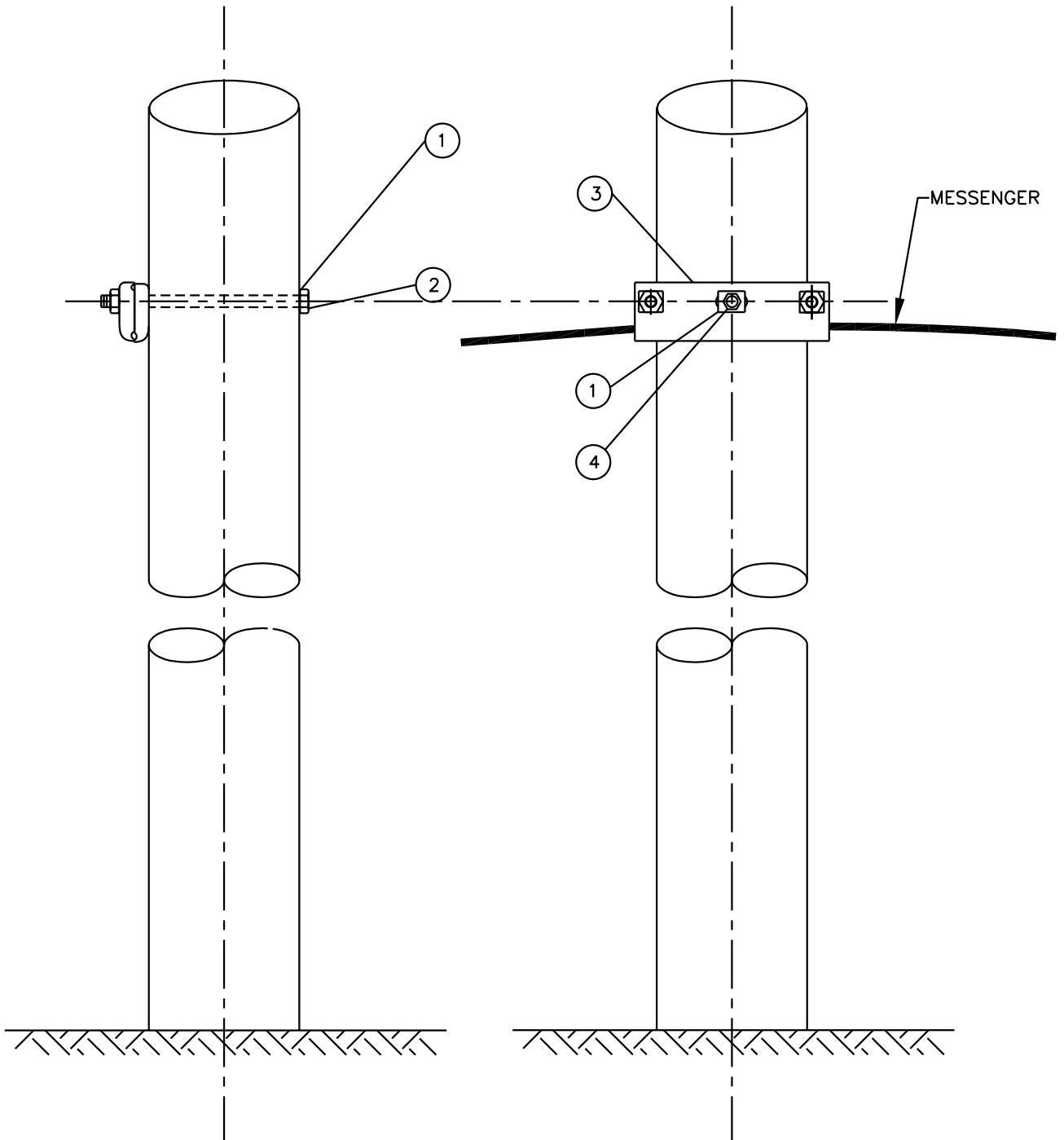

NOTE:

- 1: SALVAGED HARDWARE TO BE RETURNED TO COMMUNICATION COMPANY.
- 2: REFER TO A-28-01 FOR MOUNTING HEIGHTS AND CLEARANCE REQUIREMENTS.

SCALE: N.T.S. ALL DIMENSIONS ARE IN MILLIMETRES UNLESS OTHERWISE INDICATED

SaskPower – DISTRIBUTION STANDARDS

| | | | |
|---------------------------|-------------|---------------------|---------------------|
| DRN. A.JUTTLA | DESIGN CHK. | APPROVAL | TRANSFER MESSENGER |
| CHKD. | | | |
| DATE | DATE | DATE | |
| DATE OF ISSUE: 2003/05/30 | | DRAWING NO. A-28-05 | SHEET 2 of 2 REV. A |